

W e . s u p p o r t . t h e  
i n n o v a t i o n s . o f . c u s t o m e r s

# Leak - Proof Flow & Control Solution Partner

The Best Partner  
for Value Creation

**S-LOK®** Manifold & Gauge & Rising Plug Valves

**HanSun**

한선엔지니어링(주)  
HANSUN ENGINEERING CO., LTD.



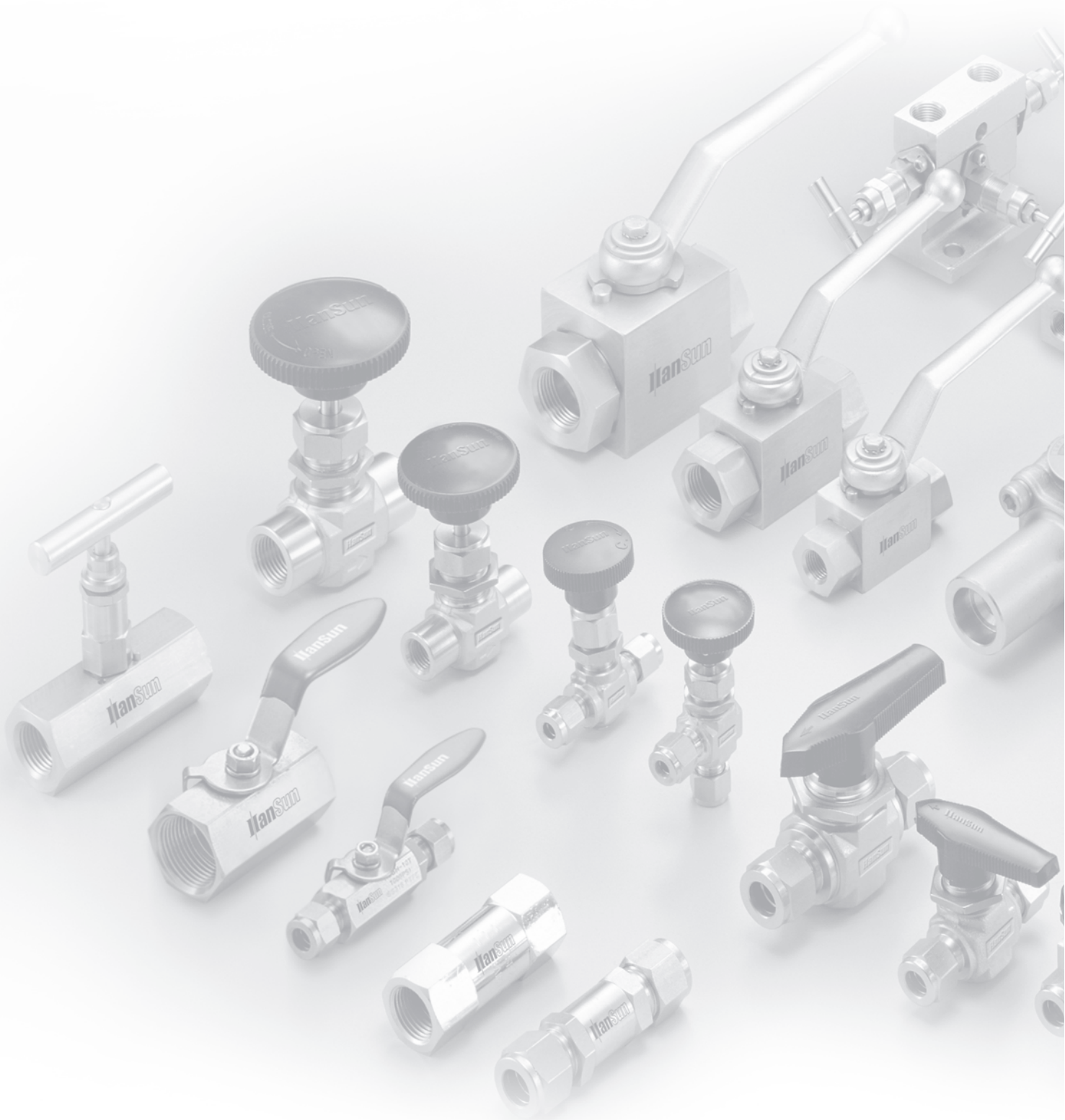

## Manifold Valves

### SMV SERIES

**SMV**  
Series

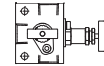

4~11

**SMVD**  
Series

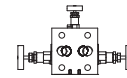

12~13

## Gauge & Gauge Root valves

### SGV60, SGRV60, SGRLV60 SERIES

**SGV60**  
**SGRV60**  
**SGRLV60**  
Series

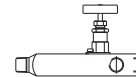

14~16

## Rising Plug Valves

### SRPV60 SERIES

**SRPV60**  
Series



17~19

We · support · the  
innovations · of · customers

# Leak - Proof Flow & Control Solution Partner

The Best Partner  
for Value Creation

**S-LOK®** Manifold Valves

## Manifold Valves

---



**SMV, SMVD**

## Product Information

### Materials of Construction

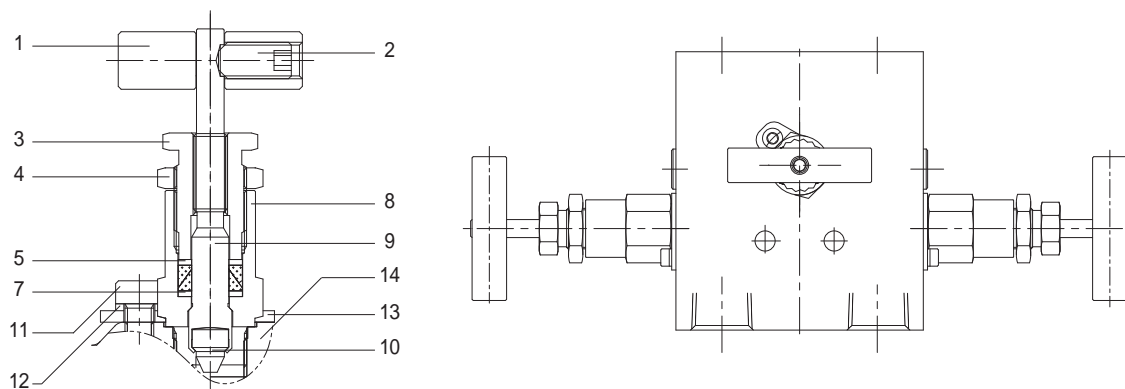

Component	Valve Body Materials	
	Stainless Steel	Carbon Steel
	Bonnet Valve	
	Grade/ASTM Specification	
1.Handle	Stainless steel	Aluminum black anodized
2.Set screw	S316 / A276 or A479	S316 / A276 or A479
3.Packing bolt		C.Steel / A108
4.Lock nut		S316 / A276 or A479
5.Upper gland		
6.Packing	Standard chevron PTFE packing, optional Graphite	
7.Lower gland	S316 / A276 or A479	S316 / A276 or A479
8.Bonnet		C.Steel / A108
9.Stem		S316 / A276 or A479
10.Non-rotating stem tip	S630 / A564	
11.Lock plate bolt	Stainless steel	
12.Spring washer	Stainless steel	
13.Lock plate	Stainless steel	Carbon steel
14.Body	S316 / A276 or A479	C.Steel / A108 or A105 Yellow zinc alvanized
Flange seals (not shown)	PTFE / D1710, optional Graphite and Fluorocarbon FKM O-ring	
Flange bolts (not shown)	Stainless steel / A193	Carbon steel / A193
Lubricant	Fluorinated base with PTFE and tungsten disulfide	
	Hydrocarbon based	

## Product Information

### Features

- Non-rotating stem tip at closure for long-life and leak-tight shutoff. Blunt VEE tip.
- Exclusive 2-piece, chevron PTFE packing design provides far improved sealing integrity. Grafoil packing optional.
- Isolated Threads : Packing located below the threads prevents media contamination and thread lubricant washout.
- Packing under the stem threads is to isolate the threads from the system fluid and lubricant washout.
- Packing bolt permits stem packing adjustment.

### Features

Packing Material	Body Material	Temperature Range	Pressure Rating @100°F	Pressure Rating @Max. Temperature
Stainless Steel	PTFE	-54~232°C (-65~450°F)	413bar (6,000 psig)	4,130psig @450°F (285bar @232°C)
	Graphite	-54~648°C(1) (-65~1,200°F)		1,715psig @1,200°F (118bar @648°C)
Carbon Steel	PTFE	-29~176°C (-20~350°F)	413bar (6,000 psig)	5,230psig @350°F (360bar @176°C)
	Graphite	-29~176°C (-20~350°F)		



(1) Graphite packing rating is limited to 537°C(1,000°F) with flange end connection. In air, Graphite rating is limited 523°C (975°F), in steam it can go up to the maximum temperature of 648°C (1,200°F).

- -28 to 204°C (-18 to 399°F) with optional fluorocarbon FKM flange seal.

### Testing

- Each instrument manifold is tested with nitrogen@1,000 psig (69 bar) to max. leak rate of 0.1 (SSCM).
- Hydrostatic shell test is performed at 1.5 times the working pressure as an option.
- Other tests are available upon request

### Sour Gas Service

- For the use of valves on sour gas, materials for wetted components are selected in accordance with NACE standard as MR0175, latest revision.

### How to Order Manifolds with Options

- To order the optional Grafoil packing, add-GF to the ordering number. SM3V-F-8N-GF-S6
- To order sour gas service valve, add-SG to the ordering number. SM3V-F-8N-GF-SG-S6
- To complete the ordering number, select valve body material designator -S6 for S316, -CS for carbon steel, Example: SM3V-F-8N-S6
- Packing adjustment : Extreme or rapid temperature cycle may require packing adjustment to maintain a leak-free system. Tightening the Locknut on the bonnet is for the packing adjustment.

## Product Information

2-Valve	3-Valve	5-Valve
For isolating, calibrating and draining Pressure gauges and transmitters.	For measuring flow or leveling using A differential pressure transmitter.	For measuring flow or level using a differential pressure transmitter or gauge with bleeding, calibration and test function.
<p>In operation, the block valve is normally open when the bleed valve is closed. To remove the instrument, close the block valve fist, and open the bleed valve to relieve pressure at the upstream of the block valve.</p> <p>For calibration, connecting a calibration gauge to the bleed port allows checking the calibration of the instrument without removing it from the installation.</p>	<p>In operation, both block valves are open while the equalizer valve is closed to read a differential pressure to the pressure gauge or transmitter. To zero the instrument, close the block valve first then open the equalizer valve which will adjust the instrument to zero.</p> <p>To remove the instrument, close block valves first, then unscrew the bleeding plug to relieve pressure between the manifold and instrument.</p>	<p>In operation, both block valves are open while the equalizer and bleed valves are closed to read a differential pressure to pressure gauge or transmitter. To zero the instrument, close block valves and bleed valve, and open the equalizer valve which will adjust the instrument to zero.</p> <p>For calibration, connect the bleed port to a pressure gauge to check the calibration of the instrument.</p>

## Ordering and Technical Information

Manifolds		Basic Ordering Number	End Connection		Orifice mm (in.)	Weight kg (lb.)
			Process	Instrument		
Remote Mount	Block	SM2V-F-8N	1/2 in. Female NPT		3.2 (.126)	0.8 (1.8)
		SM3V-F-8N			6.4 (.251)	2.0 (4.4)
		SM5V-F-8N				2.2 (4.9)
	Single Flange	SM2V1-F-8N	1/2 in. Female NPT to Flange Flange design meets MSS SP-99.		3.2 (.126)	1.0 (2.2)
		SM3V1-F-8N			6.4 (.251)	2.2 (4.9)
		SM5V1-F-8N				2.7 (6.0)
	Double Flange	SM3V2	Flange to Flange. Flange design meets MSS SP-99.		6.4 (.251)	2.5 (5.5)
		SM5V2				2.7 (6.0)
	Single Flange with slotted feature	SM2V1S-F-8N	1/2 in. Female NPT to Flange. Flange design meets MSS SP-99.		3.2 (.126)	1.0 (2.2)
		SM3V1S-F-8N			6.4 (.251)	2.2 (4.9)
		SM5V1S-F-8N				2.7 (6.0)
	Double Flange with feature	SM3V2S	Flange to Flange. Flange design meets MSS SP-99		6.4 (.251)	2.5 (5.5)
		SM5V2S				2.7 (6.0)
	Direct Mount	Vertical	SM2VD-F-8N	1/2 in. Female NPT to Flange, Flange design meets MSS SP-99.		3.2 (.126)
SM3VD-F-8N			5.0 (.196)			1.7 (3.8)
SM5VD-F-8N			6.4 (.251)			3.3 (7.3)
SM5VDS-F-8N			5.0 (.196)			2.7 (6.0)

- To complete the ordering number, select valve material designator.  
-S6 for S316, -CS for Carbon steel. Example : SM2V-F-8N-GF-S6/CS
- To order optional Graphite packing, add -GF to the ordering number. Example : SM2V-F-8N-GF-S6
- To order sour gas service valve, add -SG to the ordering number. Example : SM2V-F-8N-GF-SG-S6

# Product Information

## Remote Mount

### SM2V-F-8N

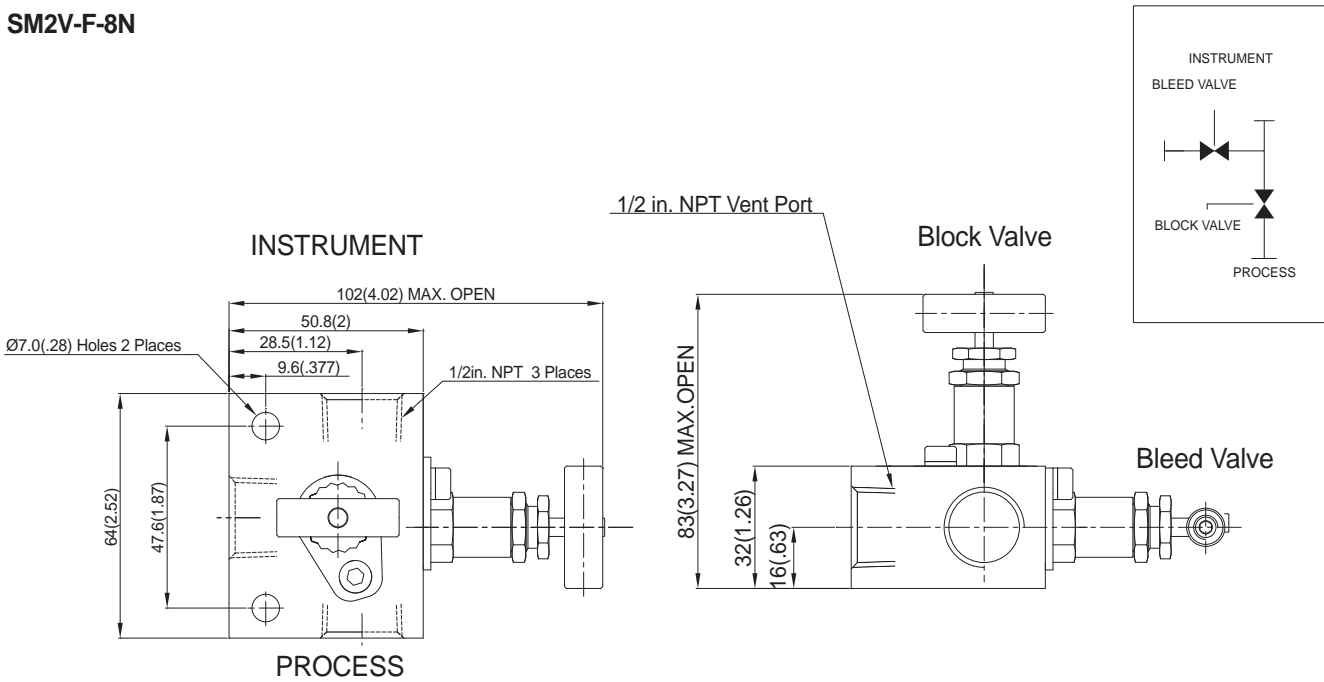

### SM3V-F-8N

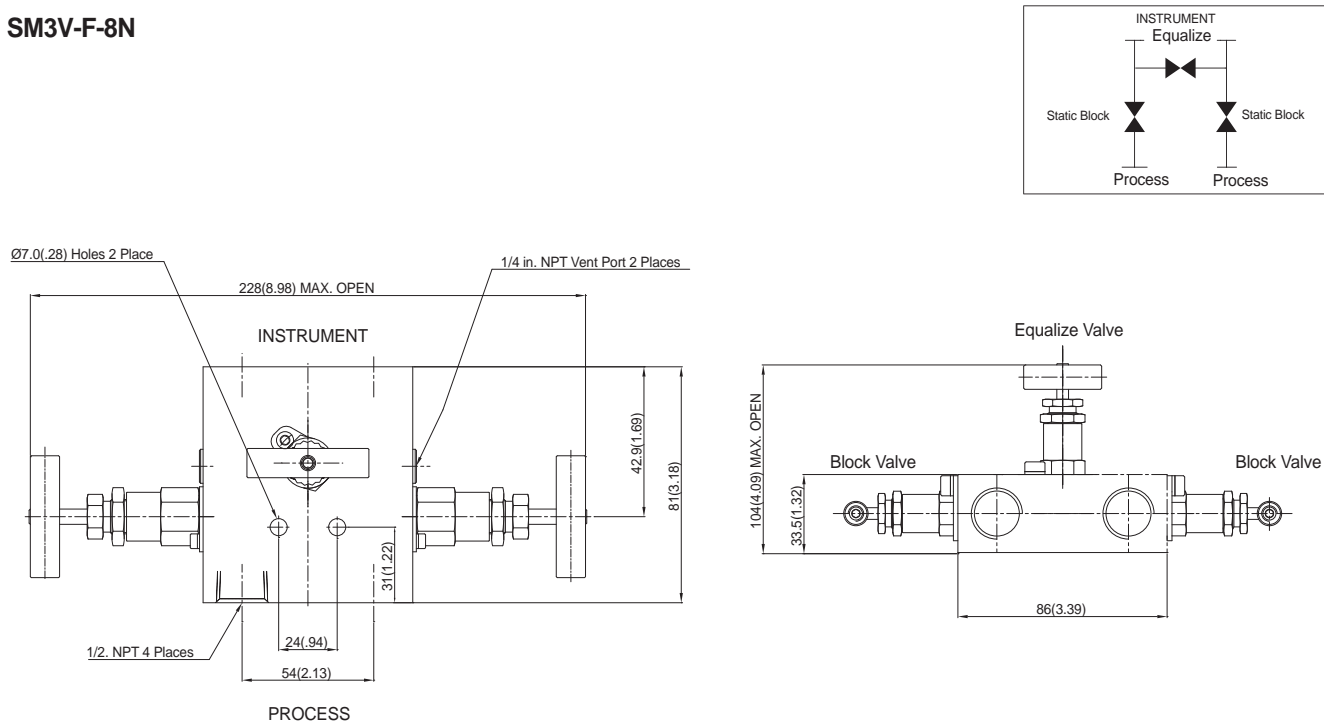



# Product Information

## Remote Mount

### SM5V-F-8N

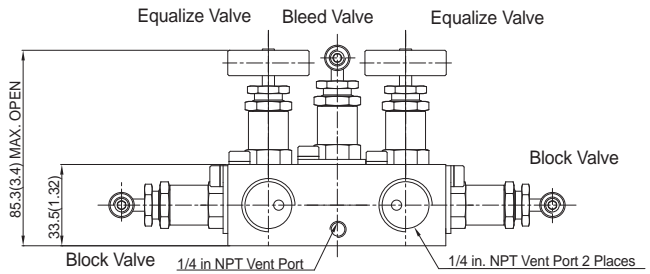
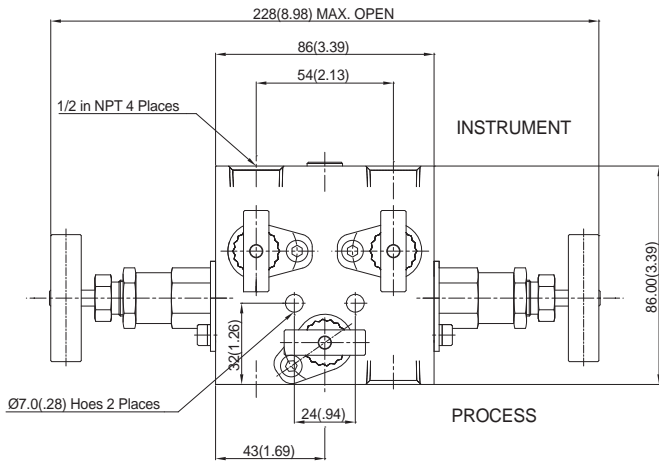
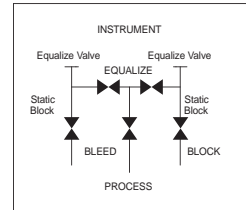

### SM2V1-F-8N / SM2V1S-F-8N

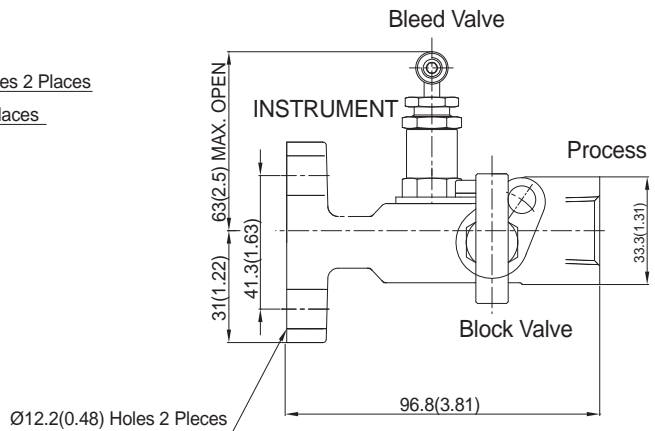
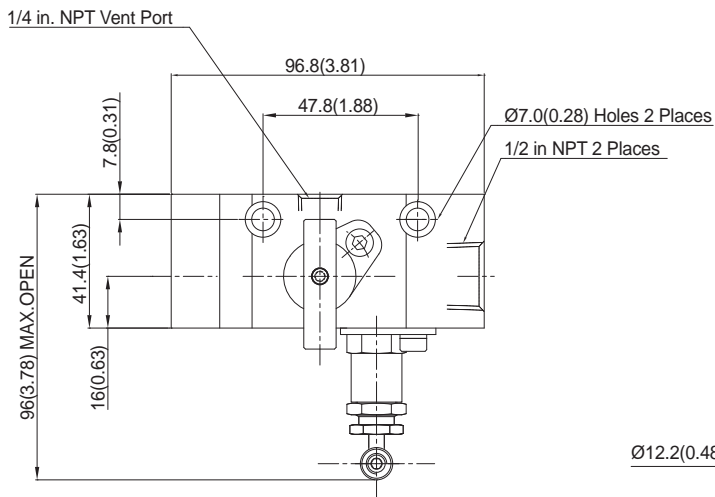
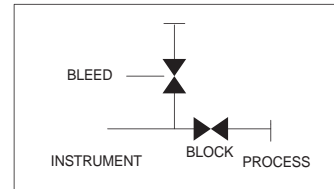

# Product Information

## Remote Mount

### SM3V-F-8N / SM3V1S-F-8N

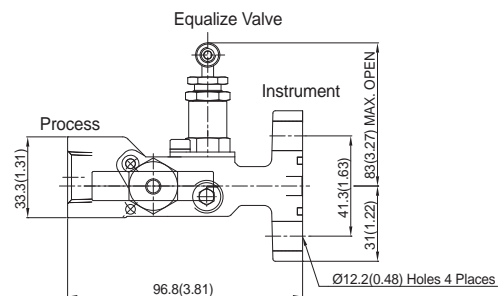
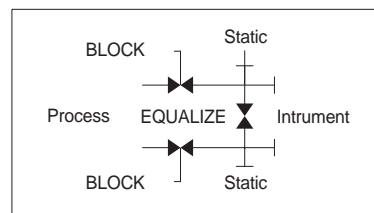
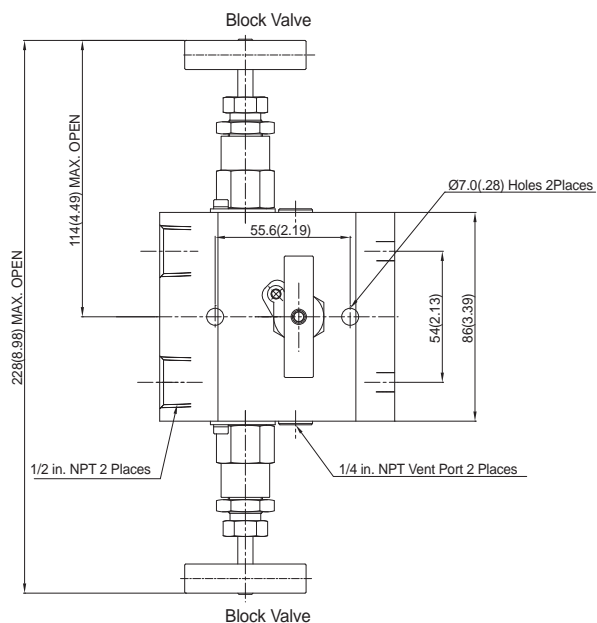

### SM5V-F-8N / SM5V1S-F-8N

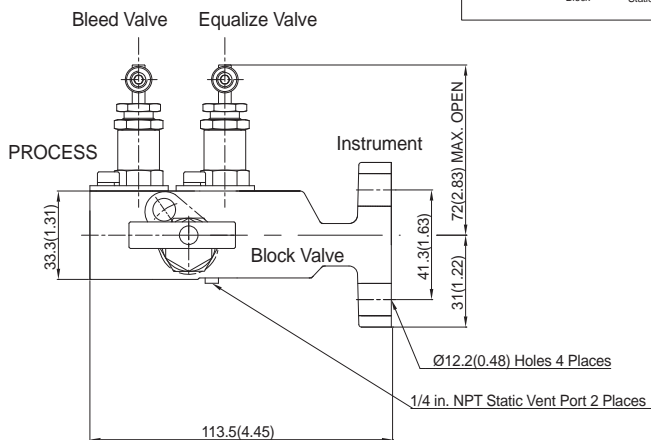
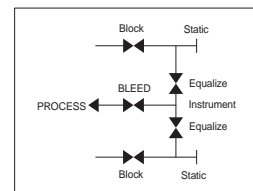
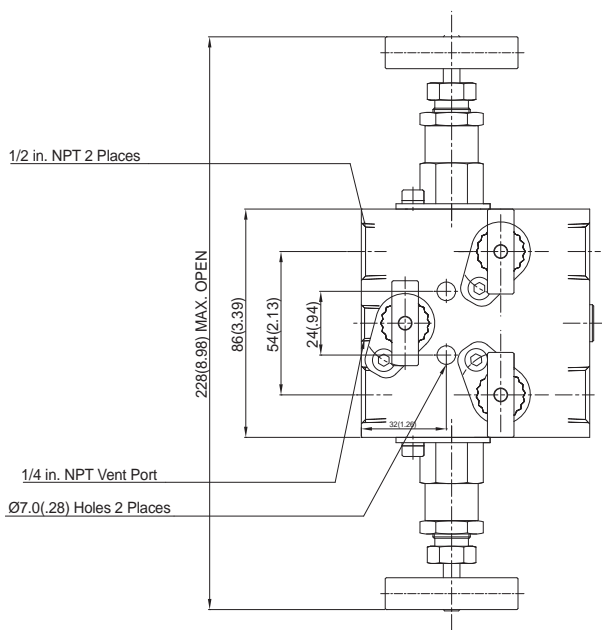

# Product Information

## Remote Mount

### SM3V2- / SM3V2S-

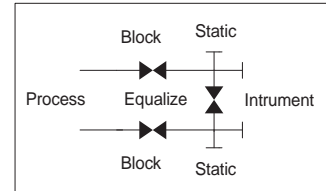
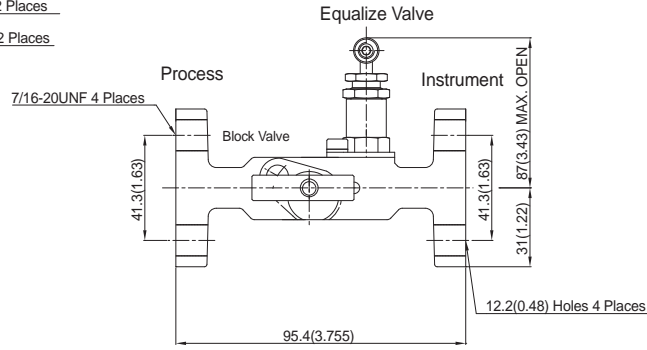
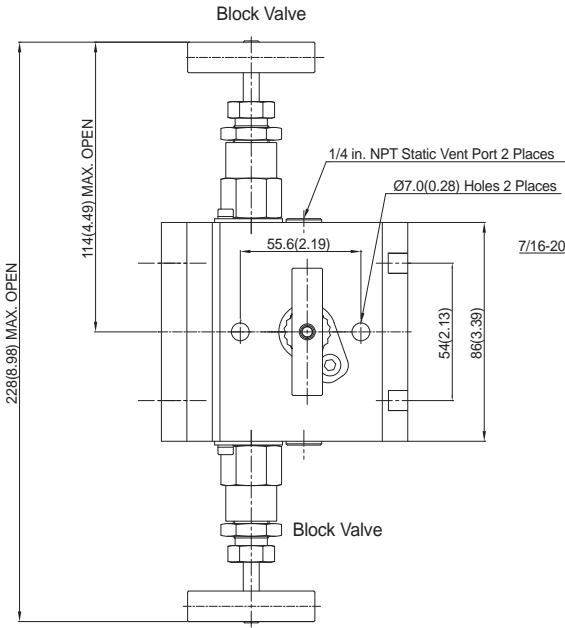

### SM5V2- / SM5V2S-

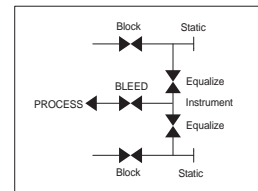
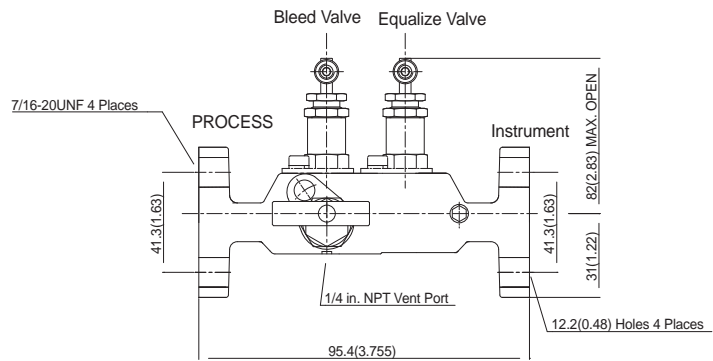
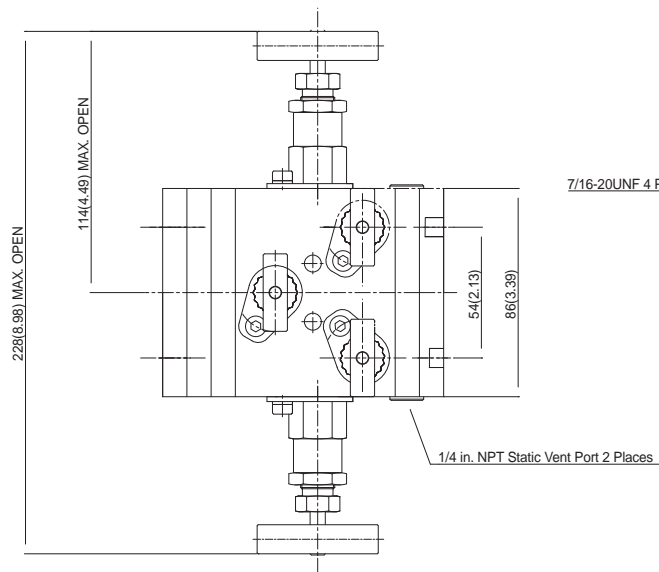

# Product Information

## Vertical Direct Mount

### SM2VD-F-8N-

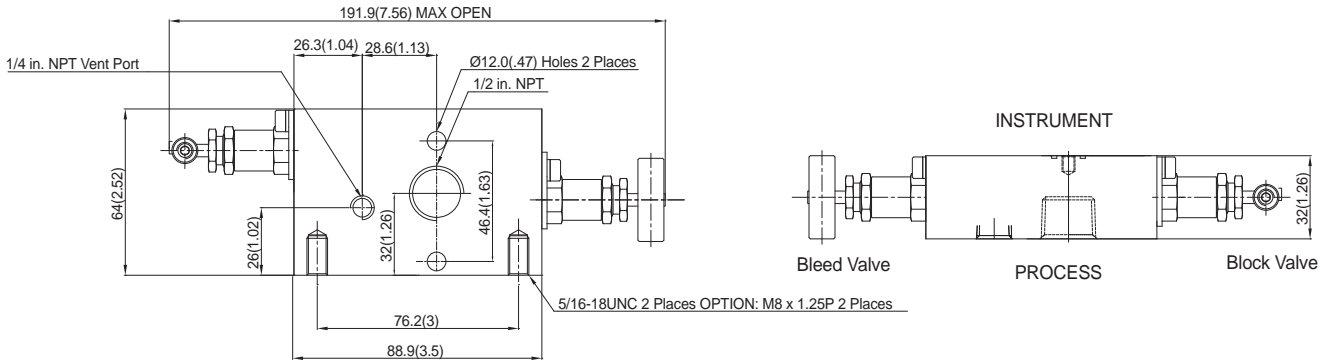
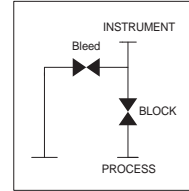

### SM3VD-F-8N

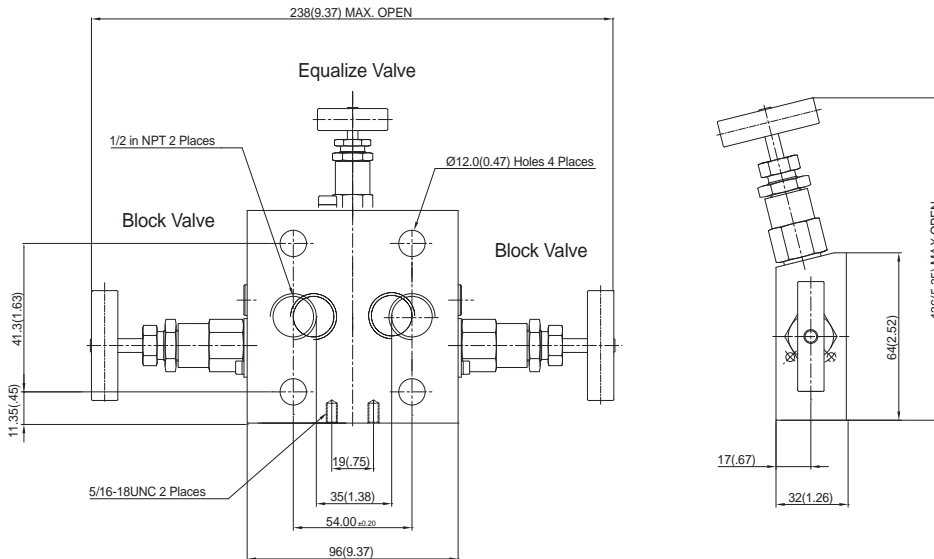
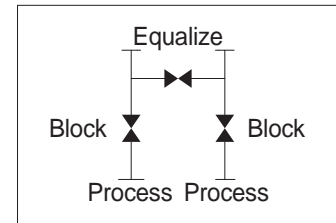

# Product Information

## Vertical Direct Mount

### SM5VD-F-8N

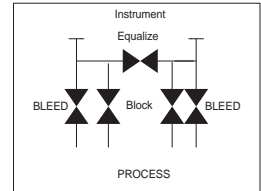
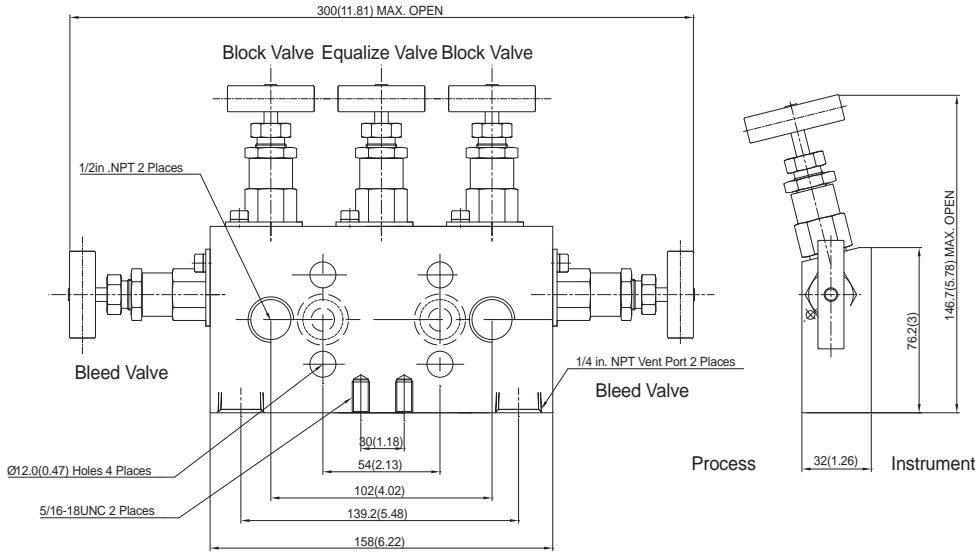

### SM5VDS-F-8N

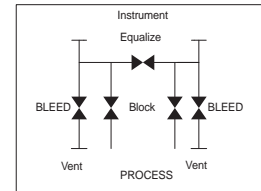
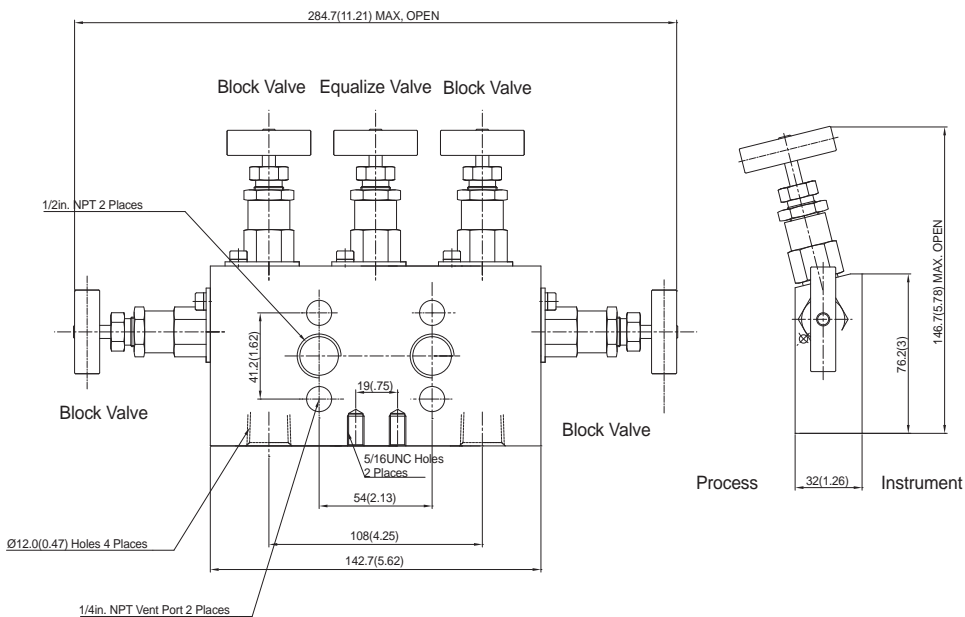

We · support · the  
i n n o v a t i o n s · o f · c u s t o m e r s

# Leak - Proof Flow & Control Solution Partner

The Best Partner  
for Value Creation

**S-LOK**® Gauge & Gauge Root Valves

## Gauge & Gauge Root valves

---



**SGV60, SGRV60, SGRLV60**

## Product Information

### Features

- The number of 1/2" female NPT Gauge Port
- SGRV has extended 4.0" body for pipe insulation

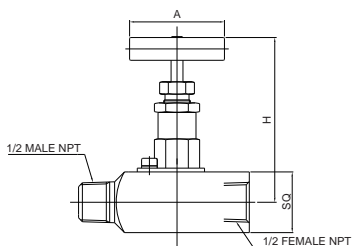

SGV Gauge Valve

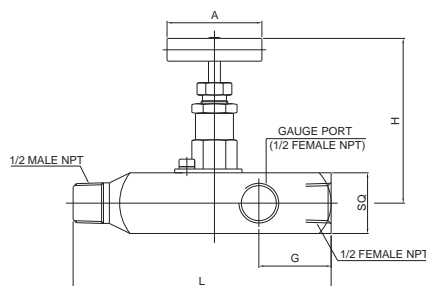

SGRV Gauge Root Valve

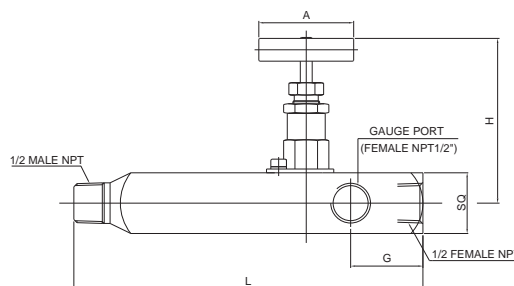

SGRLV Extended Gauge Root Valve

### Table of Dimensions and Ordering Information

Valve Ordering Number	End Connection NPT	Orifice mm(in.)	Body Length mm(in.)L	MAX. OPEN mm (in.) H	SQ mm(in)	G mm(in.)	A mm(in.)
SGV-MF-8N	1/2 Male to 1/2 Female	6.4 (0.25)	90.0(3.54)	86.7 (3.41)	32 (1.26)	38.10 (1.50)	64.00 (2.52)
SGRV-MF-8N	1/2 Male to 1/2 Female		137.0(5.39)				
SGRV-MF-12N-8N	3/4 Male to 1/2 Female		137.0(5.39)				
SGRLV-MF-8N	1/2 Male to 1/2 Female		184.0(7.24)				
SGRLV-MF-12N-8N	3/4 Male to 1/2 Female		184.0(7.24)				

### Pressure-Temperature Ratings

Packing Material	Body Material	Temperature Range	Pressure Rating@100°F	Pressure Rating @Max. Temperature
Stainless Steel	PTFE	-54~232°C (-65~450°F)	413bar (6,000 psig)	4,130psig @ 450°F (285bar @232°C)
	Graphite	-54~648°C(1) (-65~1,200°F)		1,715psig @ 1,200°F (118bar @648°C)
Carbon Steel	PTFE	-29~176°C (-20~350°F)	413bar (6,000 psig)	5.230psig @ 350°F (360bar @176°C)
	Graphite	-29~176°C (-20~350°F)		

(1) Optional Grafoil packing for high temperature is available.

Graphite packing rating is limited to 537°C(1,000°F) with flange end connection. In air, Graphite rating is limited 523°C(975°F),

(2) in steam it can go up to the maximum temperature of 648°C (1,200°F).

-28 to 204°C (-18 to 399°F) with optional fluorocarbon FKM flange seal.

## Product Information

### Testing

- Each instrument manifold is tested with nitrogen @ 1,000 psig (69 bar) to max. leak rate of 0.1 (SSCM).
- Hydrostatic shell test is performed at 1.5 times the working pressure as an option.
- Other tests are available upon request.

### How to Order

- To complete the ordering number, select valve body material designator -S6 for S316, -CS for carbon steel, Example:SGRV-MF-8N-S6
- To order, use-GF as suffix to the ordering number, Example: SGRV-MF-8N-GF-S6
- To order sour gas service valve, add-SG to the ordering number. Example:SGRV-MF-8N-SG-S6

### Safe Valve Selection

The selection of a valve for any application or system design must be considered to ensure safe performance. Valve function, valve rating, material compatibility, proper installation, operation and maintenance remain the sole responsibility of the system designer and the user. S-LOK accepts no liability for any improper selection, installation, operation or maintenance.



We support the  
innovations of customers

# Leak - Proof Flow & Control Solution Partner

The Best Partner  
for Value Creation

**S-LOK** Rising Plug Valves

## Rising Plug Valves

---



**SRPV60**

## Product Information

### Features

- Bi-directional flow control.
- Replaceable seat design: Acetal seat standard, optional PEEK and PFA are available.
- Non-rotating Stem Tip are composed for positive sealing and maximize soft seat life.
- Internal bonnet O-ring protects threads from external contamination.
- Isolated threads' location above the sealing rings prevent media contamination and thread lubricant washout.

### Materials of Construction

Ratings are based on standard stem tip of FKM O-ring and PTFE backup rings.

Component	Grade/ASTM Specification
1 Handle, Set screw	S316 / A276
2 Bonnet O-ring	FKM O-ring
3 Stem Shank	S316 / A276 or A479
4 Stem Tip	
5 Seat	Acetal / D4181, Optional : PEEK, PFA
6 Stem tip O-ring	FKM O-ring
7 Backup Rings (2)	PTFE / D1710
8 Bonnet	S316 / A276 or A479
9 Locking Nut	
10 Body	S316 / A276 or A479

Wetted components are listed in Red.

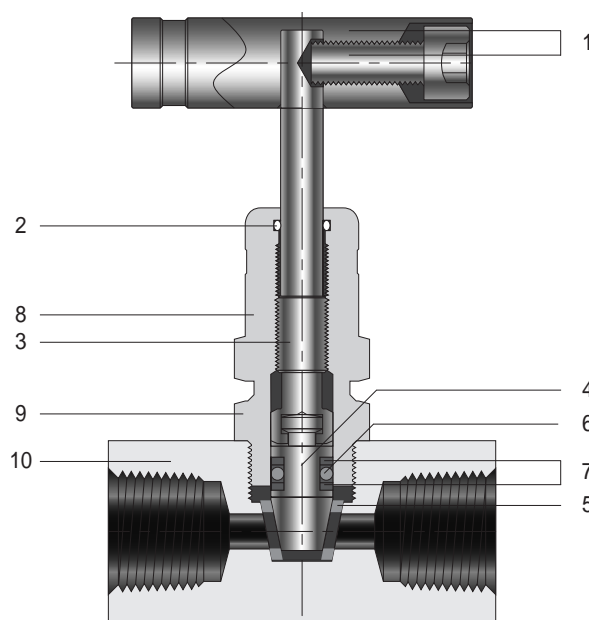

### Pressure-Temperature Ratings

Ratings are based on standard stem tip of FKM O-ring and PTFE backup rings.

Body Material	S316		
	Acetal	PEEK	PFA
Temperature °F(°C)	Working Pressure, psig(barg)		
-20 to 100 (-28 to 37)	6,000(413)	6,000(413)	750(51.6)
200 (93)	2,650(182)	3,000(206)	625(43.0)
250 (121)	1,000(68.9)	1,600(110)	450(31.0)
300 (148)	-	1,300(89.5)	300(20.6)
350 (176)	-	1,200(82.6)	200(13.7)
400 (204)	-	1,000(68.9)	100(6.8)

Valve with Actal seat : For water and steam application, standard valve with Acetal seat is not recommended for application of greater than 200°F (93°C) temperature.



## Product Information

### Ordering information and Dimensions

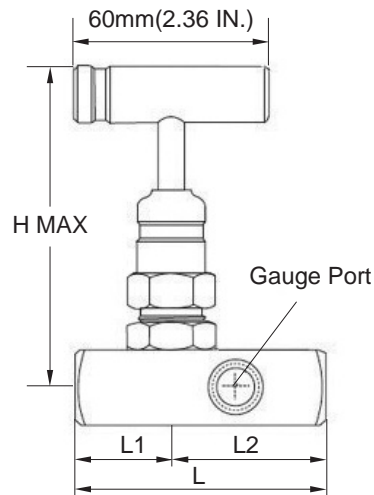

Basic Ordering Number		End Connections		Orifice Mm (in.)	Cv	Dimensions, mm(in.)			
		Inlet	Outlet			L	L1	L2	H
SRPV1-	F-4N	1/4 F NPT		4.8 (0.187)	0.63	56.9 (2.24)	28.4 (1.12)	28.4 (1.12)	95.8 (3.77)
	MF-4N	1/4 M NPT	1/4 F NPT			73.4 (2.90)	45.2 (1.78)		
	MF-8N4N	1/2 M NPT	1/4 F NPT			76.5 (3.01)	48.0 (1.89)		
SRPV1-G4-	F-4N	1/4 F NPT				72.9 (2.87)	28.4 (1.12)	44.4 (1.75)	
	MF-8N4N	1/2 M NPT	1/4 F NPT			124 (4.87)	79.2 (3.12)		
SRPV2-	F-8N	1/2 F NPT				6.2 (0.24)	1.8	67.6 (2.66)	
	MF-8N	1/2 M NPT	1/2 F NPT	88.6 (3.49)	54.9 (2.16)				
	MF-12N8N	3/4 M NPT	1/2 F NPT	90.9 (3.58)	33.8 (1.33)				
SRPV2-G8-	F-8N	1/2 F NPT		90.9 (3.58)	33.8 (1.33)			57.2 (2.25)	
	MF-8N	1/2 M NPT	1/2 F NPT	142 (5.58)	84.6 (3.33)				
	MF-12N8N	3/4 M NPT	1/2 F NPT						

- All dimensions shown are for reference only and are subjected to change.
- SRPV1-G4 gauge port: 1/4 in. Female NPT, SRPV2-G8: 1/2 in. Female NPT.
- Gage port valves with pipe installation extended body of 2.0 in. (50 mm) are Red.



27 Noksansandan361-ro, Gangseo-gu  
(Songjeong-dong), Busan, Korea

Tel : +82-51-899-6700, Fax : +82-51-899-6799

E-Mail : [overseas@ehansun.co.kr](mailto:overseas@ehansun.co.kr)

[sales@ehansun.co.kr](mailto:sales@ehansun.co.kr)

Website : [www.ehansun.co.kr](http://www.ehansun.co.kr), [www.slok.co.kr](http://www.slok.co.kr)